

Through bolt anchor for medium to heavy loads with ETA Assessment Option 1



SMD-CC M8 - M20 Zinc Plated



SMD-CC M6 - M20 Sherardized



SMD-CC M6 - M16 Stainless Steel A4 (316)

NEW SEISMIC

Use Conditions

- Installation in reinforced or unreinforced concrete C20/25 to C50/60
- For static and quasi static loading
- Seismic loading
- Cracked and non-cracked concrete
- Fire Rating R30 - R120
- Dry internal conditions

Typical Applications

- Medium to heavy duty anchoring in cracked and non-cracked concrete.
- Steel beams
- Base plates
- Channels
- Tracks
- Wood structures.

Approvals & Test Reports



Installation Procedures

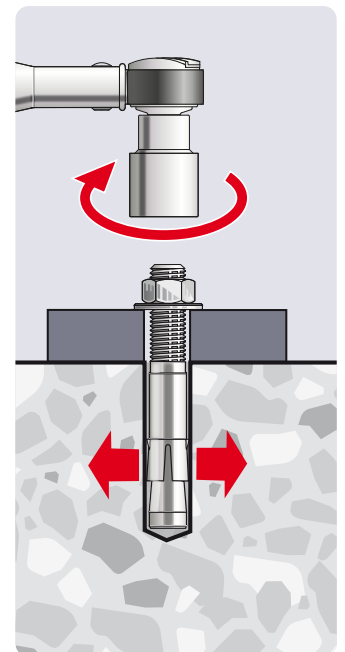
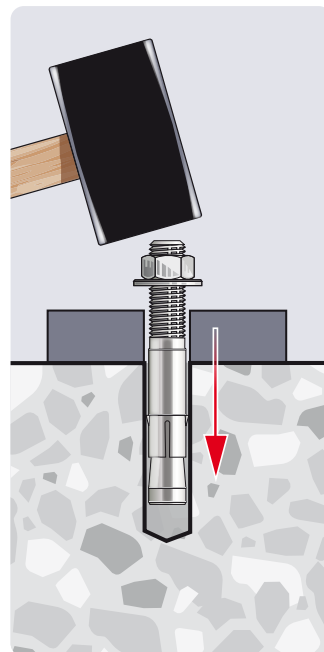
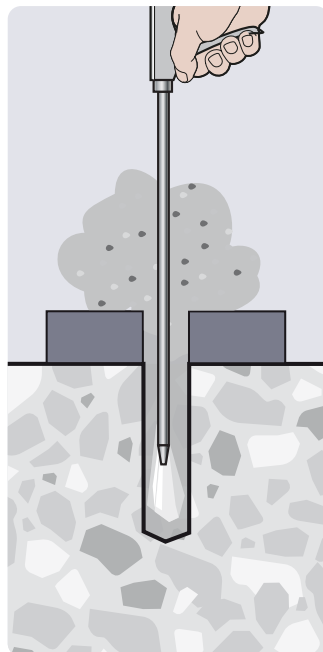
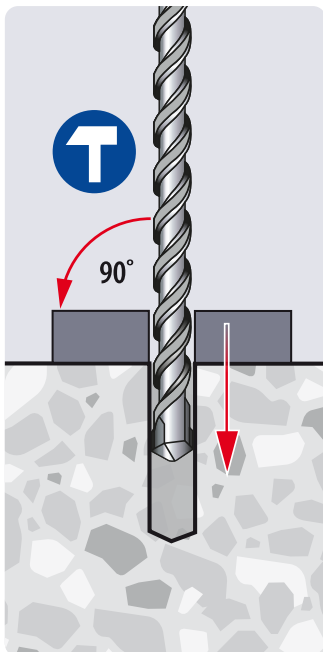

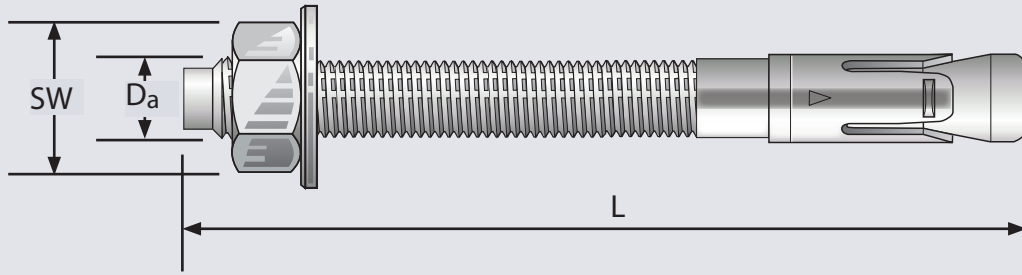

Product Dimensions

| SMD-CC | Da | m8 | m10 | m12 | m16 | m20 |
|--------------------|----------------|-----|-----|-----|-----|-----|
| Min. Anchor Length | L_{min} [mm] | 68 | 82 | 98 | 119 | 140 |
| Max. Anchor Length | L_{max} [mm] | 200 | 200 | 250 | 250 | 300 |
| Hexagon Nut | SW [mm] | 13 | 17 | 19 | 24 | 30 |

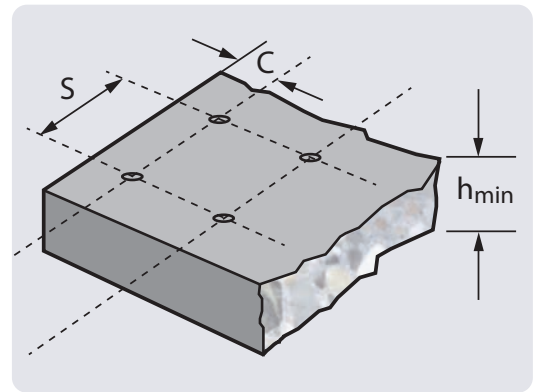
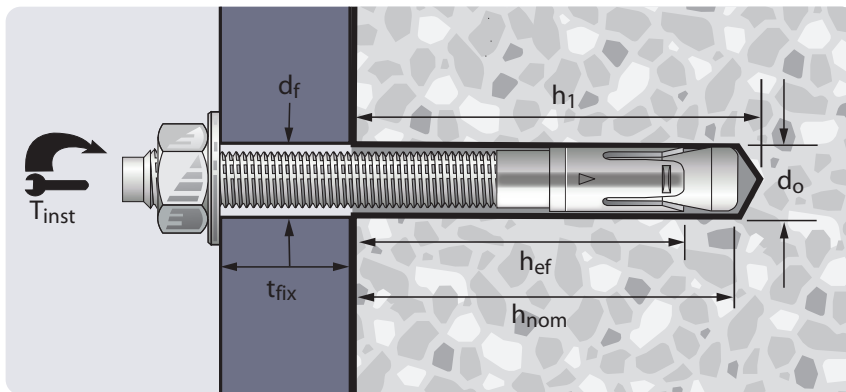

Installation Dimensions

| SMD-CC | Da | m8 | m10 | m12 | m16 | m20 |
|-------------------------|-----------------|--------|--------|--------|---------|---------|
| Hole Diameter | d_o [mm] | 8 | 10 | 12 | 16 | 20 |
| Hole Depth | h_1 [mm] | 60 | 75 | 85 | 105 | 125 |
| Overall Embedment Depth | h_{nom} [mm] | 55 | 68 | 80 | 97 | 114 |
| Eff. Anchorage Depth | h_{ef} [mm] | 48 | 60 | 70 | 85 | 100 |
| Diameter Fixture Hole | d_f [mm] | 9 | 12 | 14 | 18 | 22 |
| Fixture Height | t_{fix} [mm] | L - 66 | L - 80 | L - 96 | L - 117 | L - 138 |
| Recommended torque | T_{inst} [Nm] | 20 | 40 | 60 | 100 | 200 |

Member Thickness, Edge Distance & Spacing

| SMD-CC | Da | m8 | m10 | m12 | m16 | m20 |
|-----------------------|----------------|-----|-----|-----|-----|-----|
| Min. Member Thickness | h_{min} [mm] | 100 | 120 | 140 | 170 | 200 |
| Min. Edge Distance | C_{min} [mm] | 50 | 60 | 70 | 85 | 100 |
| Min. Spacing | S_{min} [mm] | 50 | 60 | 70 | 85 | 100 |

Performance Data¹⁾

Design Resistance

Steel Failure

| Non Cracked Concrete | | D _a | | m8 | m10 | m12 | m16 | m20 |
|----------------------|---------------------|-----------------|------|-----|------|------|------|------|
| Zinc Plated | Tensile | N _{Rd} | [kN] | 5,0 | 10,7 | 13,3 | 23,3 | 33,3 |
| | Shear ²⁾ | V _{Rd} | [kN] | 8,8 | 13,9 | 20,2 | 37,7 | 58,5 |
| Sherardized | Tensile | N _{Rd} | [kN] | 5,0 | 10,7 | 19,7 | 23,3 | 33,3 |
| | Shear ²⁾ | V _{Rd} | [kN] | 8,8 | 13,9 | 20,2 | 37,7 | 58,5 |
| Stainless Steel A4 | Tensile | N _{Rd} | [kN] | 6,0 | 10,7 | 13,3 | 23,3 | |
| | Shear ²⁾ | V _{Rd} | [kN] | 9,2 | 14,5 | 21,1 | 39,2 | |

| Cracked Concrete | | D _a | | m8 | m10 | m12 | m16 | m20 |
|--------------------|---------------------|-----------------|------|-----|------|------|------|------|
| Zinc Plated | Tensile | N _{Rd} | [kN] | 2,8 | 6,0 | 8,0 | 16,7 | 20,0 |
| | Shear ²⁾ | V _{Rd} | [kN] | 8,0 | 13,9 | 20,2 | 37,7 | 48,0 |
| Sherardized | Tensile | N _{Rd} | [kN] | 3,3 | 6,0 | 10,7 | 16,7 | 20,0 |
| | Shear ²⁾ | V _{Rd} | [kN] | 8,0 | 13,9 | 20,2 | 37,7 | 48,0 |
| Stainless Steel A4 | Tensile | N _{Rd} | [kN] | 3,3 | 6,0 | 8,0 | 16,7 | |
| | Shear ²⁾ | V _{Rd} | [kN] | 8,0 | 14,5 | 21,1 | 38,3 | |

Recommended Loads³⁾

Steel Failure

| Non Cracked Concrete | | D _a | | m8 | m10 | m12 | m16 | m20 |
|----------------------|---------------------|-----------------|------|-----|------|------|------|------|
| Zinc Plated | Tensile | N _{Rd} | [kN] | 3,6 | 7,6 | 9,5 | 16,7 | 23,8 |
| | Shear ²⁾ | V _{Rd} | [kN] | 6,3 | 9,9 | 14,5 | 26,9 | 41,8 |
| Sherardized | Tensile | N _{Rd} | [kN] | 3,6 | 7,6 | 14,1 | 16,7 | 23,8 |
| | Shear ²⁾ | V _{Rd} | [kN] | 6,3 | 9,9 | 14,5 | 26,9 | 41,8 |
| Stainless Steel A4 | Tensile | N _{Rd} | [kN] | 4,3 | 7,6 | 9,5 | 16,7 | |
| | Shear ²⁾ | V _{Rd} | [kN] | 6,5 | 10,3 | 15,1 | 28,0 | |

| Cracked Concrete | | D _a | | m8 | m10 | m12 | m16 | m20 |
|--------------------|---------------------|-----------------|------|-----|------|------|------|------|
| Zinc Plated | Tensile | N _{Rd} | [kN] | 2,0 | 4,3 | 5,7 | 11,9 | 14,3 |
| | Shear ²⁾ | V _{Rd} | [kN] | 5,7 | 9,9 | 14,5 | 26,9 | 34,3 |
| Sherardized | Tensile | N _{Rd} | [kN] | 2,4 | 4,3 | 7,6 | 11,9 | 14,3 |
| | Shear ²⁾ | V _{Rd} | [kN] | 5,7 | 9,9 | 14,5 | 26,9 | 34,3 |
| Stainless Steel A4 | Tensile | N _{Rd} | [kN] | 2,4 | 4,3 | 5,7 | 11,9 | |
| | Shear ²⁾ | V _{Rd} | [kN] | 5,7 | 10,3 | 15,1 | 27,4 | |

1) All Loads in kN for a Single anchor in Dry/Wet concrete C20/25 without edge or spacing influences. 2) Steel strength in kN without bending moment. 3) Incl. Safety factor $\gamma_G = 1,4$